

**SAFEGUARDS AND WARNINGS**

**⚠ WARNING**

Installation and servicing is only to be carried out by suitably qualified and experienced personnel.

This product is designed for use in general purpose CCTV applications and has no other purpose.

This product is designed to operate in a class 2 indoor general environment and must not be installed where exposed to rain or moisture.

This product must be powered from a class 2 isolated power source as supplied.

**CERTIFICATIONS**

This product meets the requirements of the following standards:

**Electromagnetic Compatibility**

EN55022:1995 Limits and methods of measurement of radio disturbance characteristics of information technology

EN50082-1:1992 Electromagnetic compatibility - Generic Immunity standard

**Comprising:**

IEC 801-2:1991 Electrostatic discharge

IEC 801-3:1984 Radiated electromagnetic fields

IEC 801-4:1988 Fast transient bursts

**Safety**

EN 60950:1992 Safety of information technology equipment, including electrical business equipment

**DECLARATIONS**

The manufacturer declares that the DAX unit supplied with this manual, is compliant with the EMC directive 89/336 EEC and the low voltage directive 73/23/EEC and 93/68/EEC.

**DESCRIPTION**

The DAX/VIC converts Baxall coaxial telemetry into Dome telemetry. It connects between your transmitter and dome camera in the coaxial line as shown below. The DAX/VIC requires a +12 VDC or 24 VAC class 2 isolated power supply.

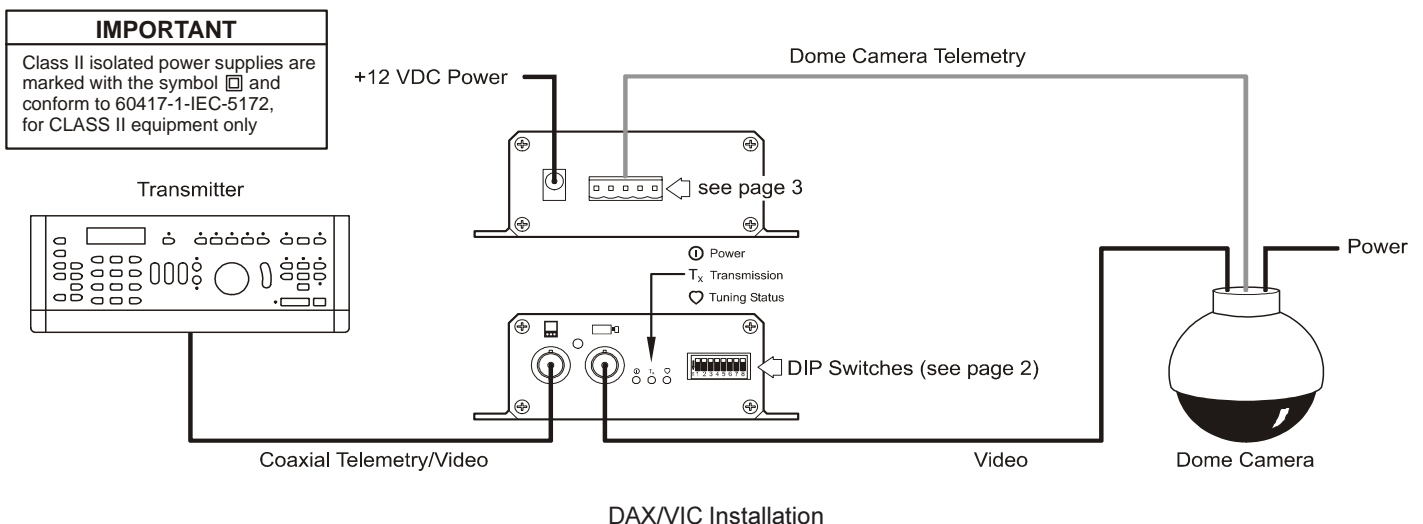

**CABLE DISTANCES**

Type	Name	Maximum Distance (m)	Medium
Coaxial	RG59/URM70	250	Video
Coaxial	RG11.CT125	500	Video
Twisted-pair	Belden 8723	1000	RS485

**SWITCH SETTINGS**

Your DAX/MIC is compatible with Vicon Industries Dome cameras of types V7UUVS, V15UUVS, Surveyor 99 and Surveyor 2000. DIP switches are used to set various modes as shown below:

- Switch 7 ON:** Enables Extended Preset mode (see below)  
**Switch 7 OFF:** Allows the Wipe key to access preset 9-16 (see below)  
**Switch 8 ON:** Dome will perform an Autopan function  
**Switch 8 OFF:** Dome will cycle (pan and tilt) through presets 1 -16

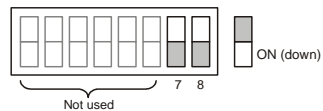
**STORING AND RECALLING PRESETS**

To store a preset using a ZTX6:

1. Press the Function (F) key.
2. Enter the preset number\*.
3. Press the Preset (X) key.

To store a preset using a ZMX:

1. Press the Function (F) key and then the Preset (X) key.
2. Enter the preset number\*.

To recall a preset using a ZTX6:

1. Enter the preset number\*.
2. Press the Preset (X) key.

To recall a preset using a ZMX:

1. Press the Preset (X) key.
2. Enter the preset number\*.

\* Preset numbers can be between 1 and 16. To enter the number for a preset that is between 1 and 8, make sure the Wipe (W) key is set to OFF and use the numbers 1 to 8 on the keyboard. To enter the number for a preset that is between 9 and 16, make sure the Wipe (W) key is set to ON and use the numbers 1 to 8 on the keyboard.

**EXTENDED FEATURES****Menu mode**

Use the following procedure to access the cameras' main menu mode:

1. Set the Camera Power (P) key on the transmitter to ON.
2. Select any preset to activate the menu.
3. Use the tilt controls to move the menu cursor up or down; use the pan controls to change menu values.
4. Use the Wash (W) key to make a menu selection.
5. Use either of the Iris keys to cancel a menu selection.
6. After completing all menu operations and clearing the menu text from the monitor screen, ensure that the Camera Power (P) key on the transmitter is set to OFF to allow correct operation of the presets.

**Setting the Speed of the Autopan function**

The speed at which the camera travels during the Autopan function can be set as follows:

1. Set the Camera Power (P) key to ON.
2. Set the Autopan (A) key to ON.
3. Use the joystick to pan the camera at the desired rate.
4. Whilst the camera is moving at the required rate, set the Autopan (A) key to OFF.
5. Set the Camera Power (P) key to OFF.

**INSTALLATION**

All video is 1V pk-pk composite via 75 ohm video coaxial cable and BNC connectors. The connections to your DAX/VIC are shown on the case and in the schematic overleaf. The camera ID number should be set to three (see your camera instructions). For best results from the auto-tune feature, ensure that a telemetry signal is being sent by the transmitter immediately after your DAX/VIC is powered up.

- Connect the +12 VDC power supply and the Dome Cameras' RS485 extension lead to the connectors on the Interface Unit according to the schematic diagram on page 1.
- Connect the Interface Module to your transmitter and to your dome camera according to the schematic.
- For Surveyor 2000 domes, set the switches on the dome camera to VPS, Simplex, RS485 and Camera three.

**SPECIFICATION**

**Inputs** : Baxall-coaxial-telemetry as defined by the Baxall coaxial telemetry specification, +12 VDC.

**Output** : Vicon Industries Camera telemetry.

**Power** : nom. +12 VDC (min. 8.0 VDC max. 24 VDC) class 2 isolated, 50mA max. (0.6 Watts); 24 VAC.

**Power Supply** : 230 VAC to +12 VDC class 2. Max 200mA.

**Dimensions** : 115 x 107 x 37 mm. (WxDxH)

**Temperature limits** : Only use this product between the temperatures of -10° and +40° C.

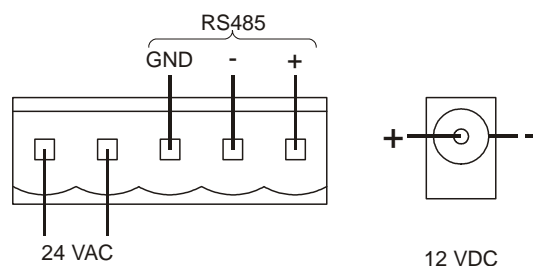
**CONNECTOR PIN-OUT****IMPORTANT:**

The 24 VAC Power supply must be a class 2 type. Do not make any connection to ground.

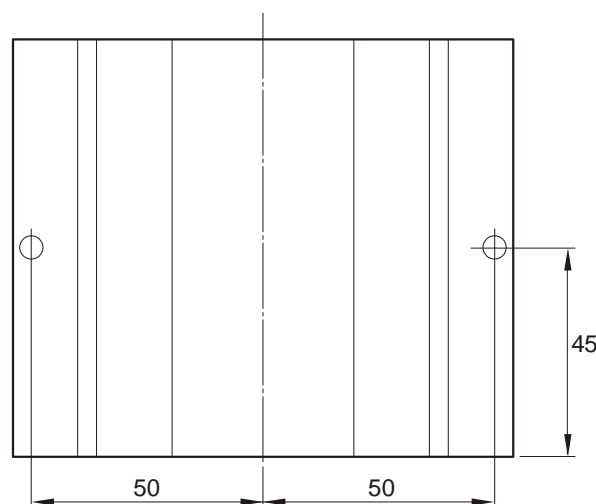
**MOUNTING**

**Baxall Limited**, Stockport, England. Visit our Web site: <http://www.baxall.com>

Baxall Limited reserve the right to make changes to the product and specification of the product without prior notice to the customer.