

SSM-175A/175ACE

Black & White Monitor



Photo: SSM-175A

The Sony SSM-175A/175ACE is a 17-inch (16-inch viewable area, measured diagonally) black-and-white monitor, offering excellent picture reproduction with its high resolution of 850 TV lines and well-focussed image.

Specifically designed for use in surveillance installations, the SSM-175A/175ACE is ideal for a wide range of applications – its large screen size making it particularly suitable for quad displays in multiple camera installations.

With its high reliability and surveillance specific features, it is designed for total customer satisfaction.

The SSM-175A/175ACE, combined with other components from the extensive range of Sony surveillance equipment, provides an ideal solution for your surveillance system.

SONY®

Features

- 17-inch (16-inch viewable area, measured diagonally) CRT with excellent focus
- High horizontal resolution of 850 TV lines
- Dual loop-through video input/output, with switchable 75 ohm termination
- DC clamp switch, providing a stable black level reference
- 19-inch EIA standard rack mountable
- Metal case provides high resistance to external electrical and magnetic interference
- Suitable for many monitoring applications

Optional Accessory

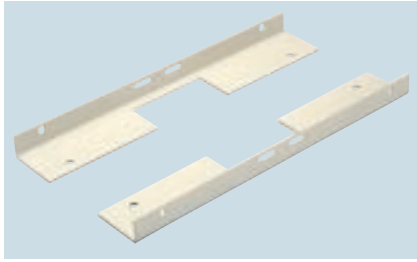

Rack Mount Bracket
RMM-171

Specifications

Video signal system:	SSM-175A: EIA standard SSM-175ACE: CCIR standard
Picture tube:	17-inch B/W (16-inch viewable area, measured diagonally), 90° deflection
Video input/output:	Composite: 0.5 to 2.0 Vp-p, sync negative, 75 ohm / high impedance switchable with loop-through output, BNC (x 2)
Horizontal resolution:	More than 850 TV lines (at center)
Power requirements:	SSM-175A: AC 120 V, 60 Hz SSM-175ACE: AC 220 to 240 V, 50/60 Hz
Power consumption:	SSM-175A: 35 W SSM-175ACE: 37 W
Operating temperature:	0 to 35 °C (32 to 95 °F) -10 to 40 °C (14 to 104 °F)
Dimensions (w/h/d):	424 × 409 × 380 mm (16 3/4 × 16 1/8 × 15 inches)
Mass:	17.5 kg (38 lb 9 oz)
Front controls:	Power, Input select, H-hold, V-hold, Contrast, Brightness
Regulation compliance:	SSM-175A: UL 1410, CSA C22.2 No.1, FCC Class-A, IC Class-A, DHHS, DNHW SSM-175ACE: EN60065, EN55022, EN50082, EN60555 (CE, C-TICK)
Supplied accessory:	Operating instruction manual

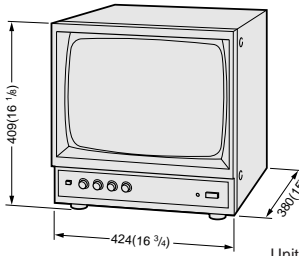

Unit: mm (inch)



Rear Panel

System Connections

1. Triple multiplexing operation

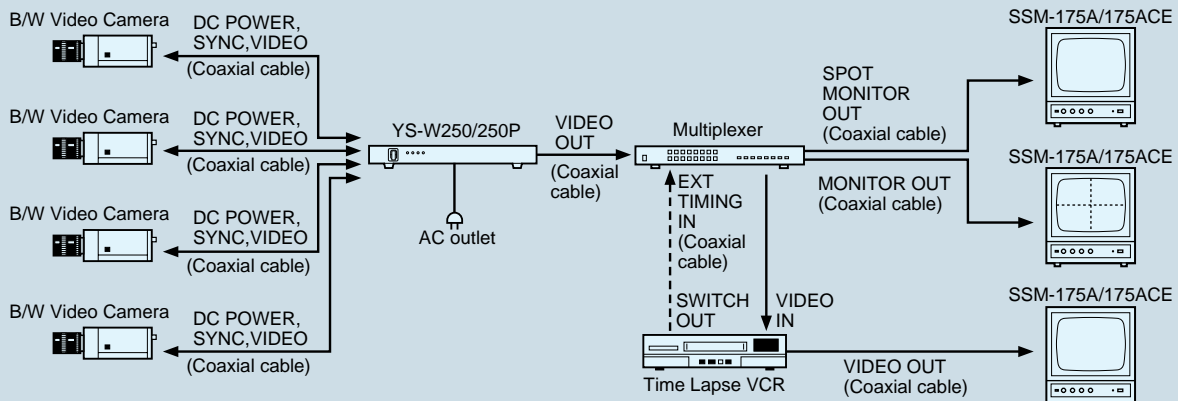

2. AC line lock operation

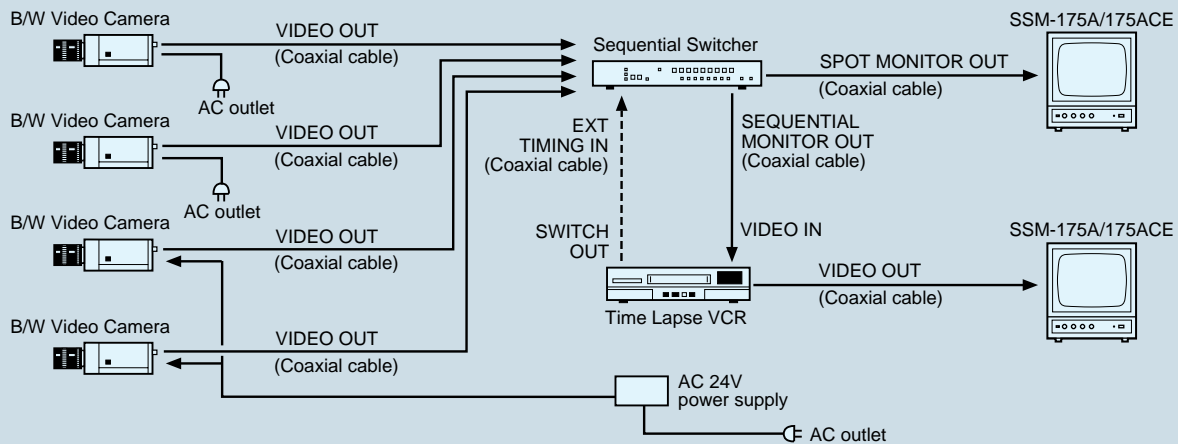

Distributed by

©1999 Sony Corporation. All rights reserved.
 Reproduction in whole or in part without written permission is prohibited.
 Features and specifications are subject to change without notice.
 All non-metric weights and measures are approximate.
 Sony is a registered trademark of Sony Corporation.