



WJ-FS409



WJ-FS416

PS•Data

INTRODUCING HIGH-PERFORMANCE, LOW-COST, DIGITAL DUPLEX COLOUR MULTIPLEXERS FROM PANASONIC.

The Panasonic WJ-FS409 (9-channel) and the WJ-FS416 (16-channel) digital duplex colour multiplexers are indispensable when constructing an accurate and efficient monitoring system.

Using the Time-Lapse VTR or WJ-HD100 digital disk recorder (sold separately), multiple channels from the monitoring cameras can be recorded in multiplex format.

Functions like multi-screen monitoring, spot monitoring, superimposed title display and electronic zoom can even be used during recording. A monitoring system using these products will not only be more efficient, but will offer better visual quality. By adding optional units such as the WJ-MP204 data multiplex unit and the WV-CU360 system controller, complex camera control sequences become incredibly simple.

Panasonic's digital duplex colour multiplexers are the key component to an effective surveillance system.

Key Features

- Digital colour duplex system.
- High picture quality of 720H × 544V pixels.
- Multiplexed video signals are supplied to the recording out.
- Playback image can be displayed in multi or full screen, via monitor output.
- The full screen image can be zoomed in two (2) times.
- Sequence mode up to 9 (WJ-FS409), or 16 (WJ-FS416) steps with dwell times.
- Built-in Panasonic Security Data (PS-Data) link mode.
- Versatile alarm recording capability.
- Built-in alphanumeric character display.
- On-screen setup menu.
- 1H(height) compact design.

Product line-up

WJ-FS409 : 9-channel camera input

WJ-FS416 : 16-channel camera input

MAJOR OPERATING CONTROLS

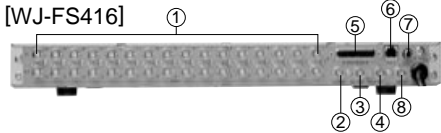
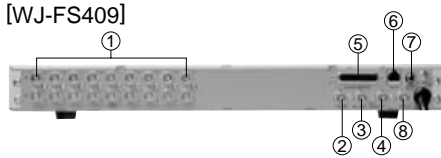
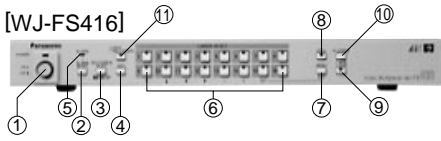
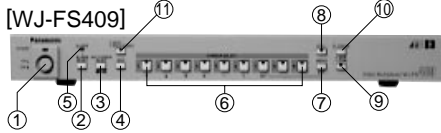

- ① Power Switch
- ② Alarm Reset Button
- ③ Multi Screen Selection Button
- ④ Sequence Button
- ⑤ Alarm Indicator
- ⑥ Camera Selection Button
- ⑦ Menu Button/ESC Button
- ⑧ Still Button
- ⑨ VTR/CAMERA Selection Button
- ⑩ Electric Zoom Button
- ⑪ Spot/Multiscreen Selection Button

- ① Video In/Out Connector
- ② Playback Input Connector
- ③ Record Output Connector
- ④ Multi Screen Output Connector
- ⑤ Alarm/Remote Control Connector
- ⑥ PS-Data Connector (RS-485) (RJ-11)
- ⑦ Camera Switching Input Connector
- ⑧ Spot Output Connector

SYSTEM EXAMPLE

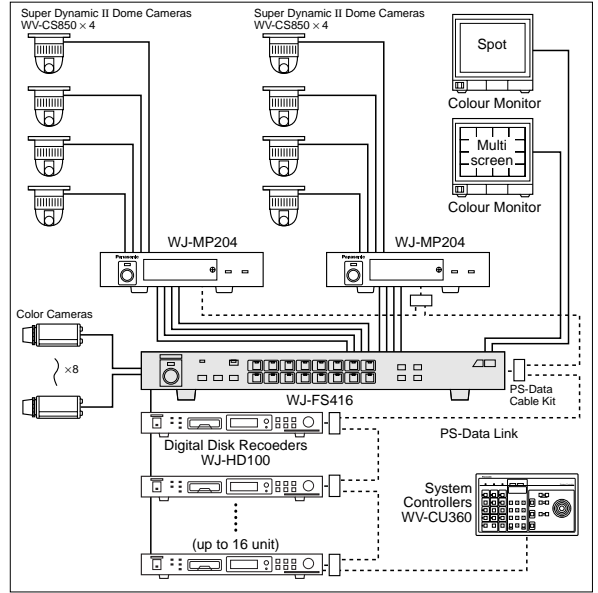

RECORDING MODE OF PANASONIC AG-6730 & SWITCHING INTERVALS

Recording Mode	2H / 6H	12H	24H	48H	72H	84H	120H	180H	240H	480H	Multiplexers
Recording Interval (Sec)	0.08	0.10	0.18	0.34	0.50	0.58	0.82	1.22	1.62	3.22	WJ-FS409/FS416
Recording Interval from ch 1 to ch 1 (Sec)	4 cameras	0.32	0.40	0.72	1.36	2.00	2.32	4.88	6.48	12.88	WJ-FS409/FS416
	9 cameras	0.72	0.90	1.62	3.06	4.50	5.22	10.98	14.58	28.98	WJ-FS409/FS416
	12 cameras	0.96	1.20	2.16	4.08	6.00	6.96	14.64	19.44	38.64	WJ-FS416
	16 cameras	1.28	1.60	2.88	5.44	8.00	9.28	19.52	25.92	51.52	WJ-FS416

*Above figures are using Panasonic Time Lapse VTR : AG-6730, SW800=off

RECORDING MODE OF PANASONIC WJ-HD100 & SWITCHING INTERVALS

Recording Mode	18H	24H	48H	72H	96H	120H	180H	240H	480H	960H	Multiplexers
Recording Interval (Sec)	0.08	0.12	0.20	0.32	0.40	0.53	0.77	1.0	2.0	5.0	WJ-FS409/FS416
Recording Interval from ch 1 to ch 1 (Sec)	4 cameras	0.32	0.48	0.80	1.29	1.60	2.11	3.08	4.0	20.0	WJ-FS409/FS416
	9 cameras	0.72	1.08	1.80	2.90	3.60	4.74	6.92	9.0	45.0	WJ-FS409/FS416
	12 cameras	0.96	1.45	2.40	3.87	4.80	6.32	9.23	12.0	60.0	WJ-FS416
	16 cameras	1.28	1.93	3.20	5.16	6.40	8.42	12.31	16.0	80.0	WJ-FS416

*Above figures are using Panasonic Digital Disk Recorder : WJ-HD100

SPECIFICATIONS PAL

Model No.	WJ-FS409	WJ-FS416
Camera Input No.	9 cameras	16 cameras
Power Source	AC220 V - 240 V , 50Hz	
Power Consumption	14W	
Camera Input	1.0 v [p-p] /75Ω 2:1 interlaced PAL composite video signal	
Playback Input	1.0 v [p-p] /75Ω PAL composite video signal	
Camera Switching Input	1RCA pin jack	
Sampling Frequency	4 fsc 17MHz	
Quantizing	8 bit	
Pixels	720H x 544V	
Minimum Switching Interval (Rec.out)	4 fields	
Spot Out	1.0 v [p-p] /75Ω PAL composite video signal	
Data Input	RS485 (RJ-11)	
Camera Output	1.0 v [p-p] /75Ω automatic termination looped through	
Recording Output	1.0 v [p-p] PAL composite video signal, multiplexed with camera ID	
Multi Screen Out	1.0 v [p-p] /75Ω composite video signal	
Alarm/Remote Control	25-pin D-sub connector	
Ambient Operating Temperature	-10°C~ +50°C	
Ambient Operating Humidity	Less than 90%	
Dimensions	420 (W) x 44 (H) x 350 (D) mm	
Weight	4kg	
Accessory	EIA 19-type rack mount bracket	

OPTIONAL COMPONENTS & ACCESSORIES

Digital Disk Recorder : WJ-HD100	PS-Data Cable Kit : WV-CA48 /10k
Data Multiplex Unit : WJ-MP204	System Controller : WV-CU360

APPEARANCE

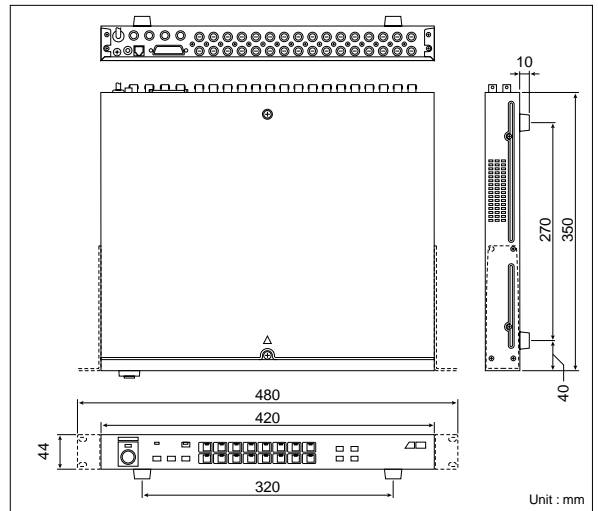

- Specifications are subject to change without notice.
- Weight and dimensions are approximate.
- These products may be subject to export control regulations.

DISTRIBUTED BY :

Panasonic

Panasonic is the brandname of Matsushita Electric.
Printed in Japan
WJ-JKFS416T(2N-677)