



RM9600 Radio Modem Application Note VISTA MULTIPLEXER / COLUMBUS DVR & REMOTE KEYBOARD RS485 Communications Over Radio (Baxnet Protocol)

Benefits

Permits wireless connectivity of the Vista NPX/BBD/J3De keyboard and NPX16gt Multiplexer or Columbus DVR

Built-in radio path test facility

Configurable frequency of operation

Configurable addressing for security

Removes RS485 data cables

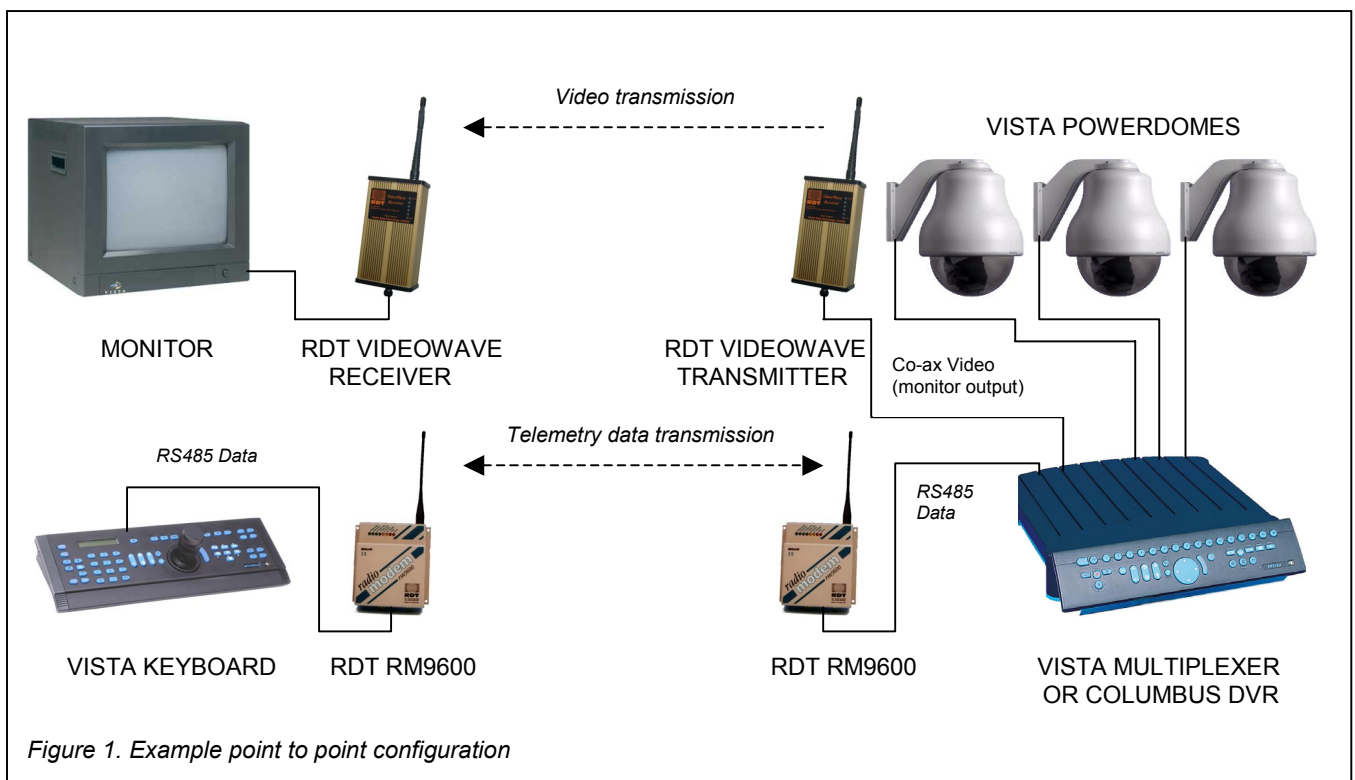

Figure 1. Example point to point configuration

Brief Description

The RM9600 Radio Modem is a secure radio data modem used for a variety of data transfer applications, including telemetry control. The use of radio for such tasks can permit a more cost-effective and flexible solution than with cabled methods. Combining the flexibility of radio data transfer with the Vista series of telemetry keyboard, multiplexers, and DVRs, permits the construction of a cost effective system with rapid installation benefits without depending upon cables.

Application note produced with the co-operation of:

Vista
Eskdale Road
Winnersh Triangle
Wokingham
Berkshire RG41 5TS

Tel: +44(0)118 944 0123
Fax: +44(0)118 944 0999
Email: sales@vista-cctv.com
Web: www.vista-cctv.com

Description of Application

The Vista NPX/BBD/J3De keyboard and NPX16gt multiplexer or Columbus DVR can communicate across the radio link utilizing the Baxnet RS485 protocol at 9600baud in half-duplex mode. Wireless video transmission is possible using the RDT Videowave series transmitters and receivers. The standard radio modem unit required at all locations is the RM9600 model, which is available in the following versions:

Part Number	Description	Antenna connection	Weatherproof
RM9600	Radio modem board module	SMA	No
RM9600B	Radio modem in aluminium enclosure	BNC	No
RM9600E	Radio modem + mains PSU in IP67 enclosure	BNC or N-type	Yes
VTX1394SED	Radio modem + 1394MHz colour video transmitter & mains PSU in IP67 enclosure	BNC or N-type	Yes
VRX1394SED	Radio modem + 1394MHz colour video receiver & mains PSU in IP67 enclosure	BNC or N-type	Yes
VTX2400ENCD	Radio modem + 2400MHz colour video transmitter & mains PSU in IP67 enclosure	BNC or N-type	Yes
VRX2400ENCD	Radio modem + 2400MHz colour video receiver & mains PSU in IP67 enclosure	BNC or N-type	Yes

Please refer to the RM9600 and videowave data sheets for further details of the above options.

The radio modem incorporates a synthesized UHF transceiver, tested to ETS 300 220-3 for operation in the UK without a license. Various approvals are held for worldwide operation. Configuration is via the rotary and DIL switches on the RM9600 which allow a band of up to 64 radio channels to be selected, (no. of channels available is dependant on regulations in the country of operation, UK specification has 15 channels), along with the serial interface baud rate, parity and character length.

Radio Modem Board Layout

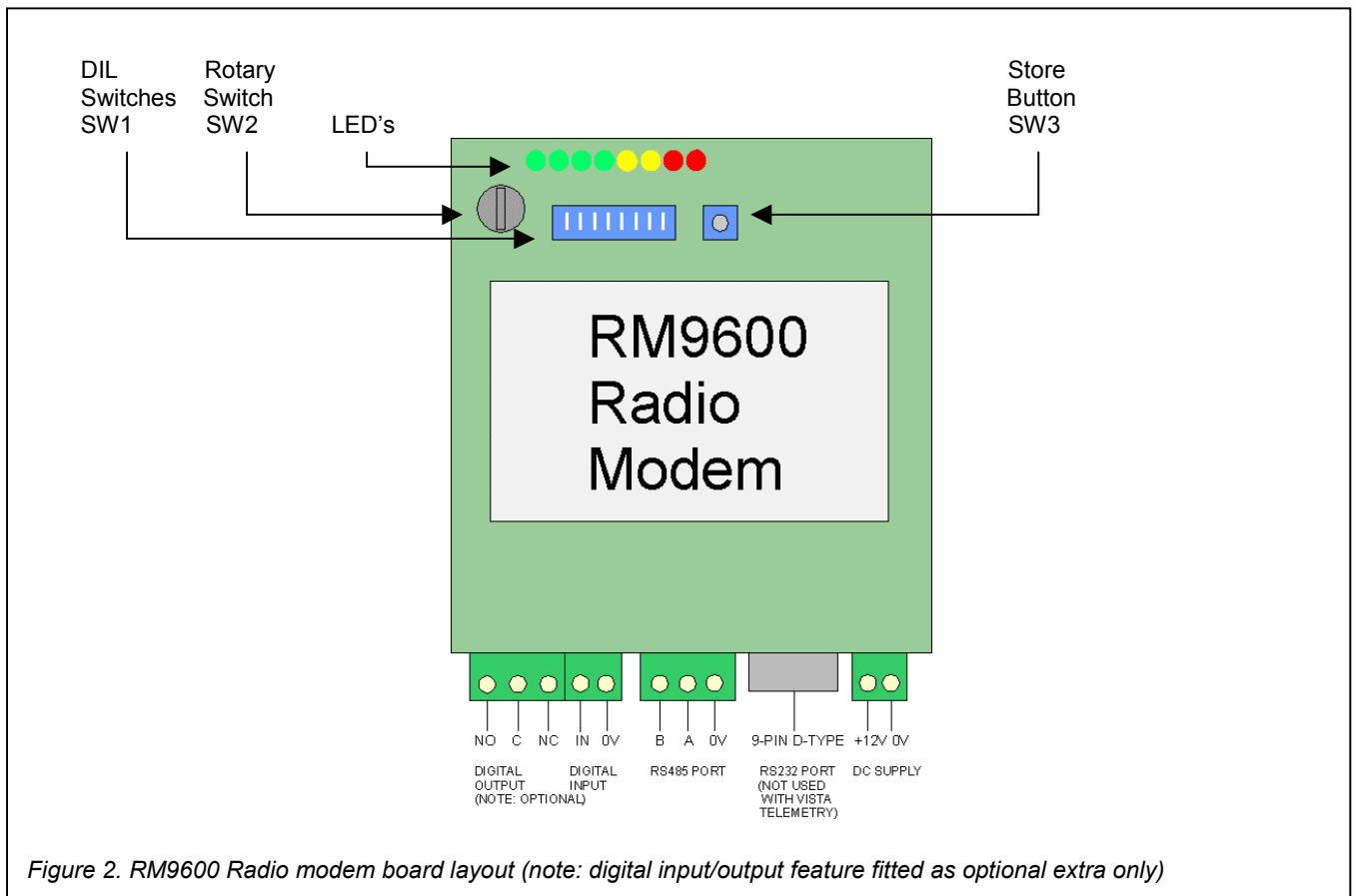

Connection and Configuration Details

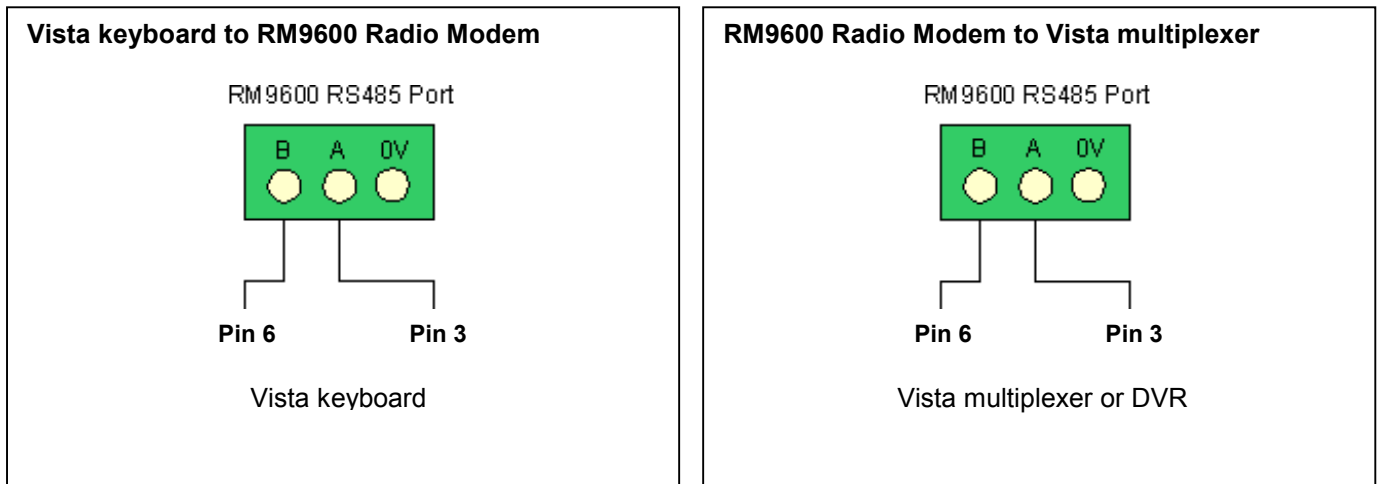

Important Note: Ensure that the antenna is connected at all times when the radio modem is powered.

How to configure each RM9600 radio modem to operate with the Vista keyboard and multiplexer:

- 1) Set the baud rate of the Vista keyboard to 9600baud (please refer to the Vista installation manual for details of this procedure).
- 2) With RM9600 powered, turn rotary switch SW2 to position F, and then press the store button SW3. This will reset the unit to factory default settings.
- 3) Turn the rotary switch SW2 to position 3. Set the DIL switches SW1 numbers 1 to 7 all OFF, and number 8 ON. Press the store button SW3. This sets the unit to RS485 operation.
- 4) Turn the rotary switch SW2 to position A. Set the DIL switches 1, 2, 3, 4, 6, & 8 OFF, and DIL switches 5 & 7 ON. Press the store button SW3.
- 5) Turn the rotary switch back to position 0.
- 6) Set DIL switches for required power level and RF channel (see RM9600 user manual). It is advised in most cases that the lowest power level be selected at first, then increase if necessary.

Note: RM9600 radio modem software version V5.06 or higher is required for correct operation with the Baxnet protocol. If using earlier versions of radio modem software, please contact RDTs technical support to check if the modem hardware is suitable for software upgrade. The radio modem software version number may be found on the EPROM located on the main PCB adjacent to store button SW3.

Antenna Selection

RDT can supply a range of antennas suitable for various applications. The table below gives an approximate guide to the distances that are achievable using different antenna types.

Part Number	Description	Range	Gain	Connection	Mounting Requirements
ANT0006A	½ wave whip. Omni-directional.	800m	-3dB	BNC	Direct to enclosure
ANT0008	End-fed dipole. Omni-directional.	5km	0dB	N-type	50mm dia. pole
ANT0009-8	8 element yagi. Directional (40°)	10km	10dB	N-type	50mm dia. pole

LED Operation

The LED's D10 to D17 on the RM9600 radio modem will provide different functions depending on the mode of operation selected by the rotary switch SW2. For example: In test mode they will indicate that the transmitter is active, or the received signal strength. In configuration modes, they will indicate the stored settings. In normal operating mode (Run Mode: Rotary switch SW2 position 0) they will indicate the following functions:

- D10 Green LED – RfCD (Carrier Detect). Indicates that the receiver is detecting a carrier signal on the selected Rf channel. For example, on a unit connected to a multiplexer this LED will illuminate when data is being received over the air from the remote Vista controller. Illumination of this LED when data is not being received may indicate interference on the selected Rf channel.
- D11 Green LED – TxFull (Buffer Full). Indicates that the RM9600's data buffer is full.
- D12 Green LED – Rx D (Receive Serial Data). Indicates that data is being received via the serial port. Illumination of this LED should be followed by D15 (RfTx) to indicate that the received serial data is being transmitted. On a unit connected to a Vista controller, if the D12 LED does not illuminate when a command is sent from the controller, check the RS485 serial data connection.
- D13 Green LED – Tx D (Transmit Serial Data). Indicates that data is being output via the serial port. For example, on a unit connected to multiplexer, this LED will illuminate following the receipt of data over the air from the Vista controller to indicate that the data is being output to the multiplexer.
- D14 Yellow LED – RfRx (Rf Receive). Indicates that the radio transceiver is currently in receive mode. This is the normal status for any unit when data is not being received via the serial port.
- D15 Yellow LED – RfTx (Rf Transmit). Indicates that the radio transceiver is currently in transmit mode. This will follow receipt of data via the serial port (indicated by illumination of the D12 LED). The status of the D15 LED will always oppose that of the D14 LED (RfRx).
- D16 Red LED - +10.5V (Supply Voltage). Indicates the presence of DC supply voltage. This LED will remain illuminated at all times when the radio modem is in run mode.
- D17 Red LED - +5V (Supply Voltage). Indicates the presence of DC supply voltage. This LED will remain illuminated at all times when the radio modem is in run mode.

Please refer to the RM9600 user manual for further information on configuration, test, and run modes.

For supply of the RM9600 radio modems or further information on this or any other application, please contact your local Vista office.

Radio Data Technology Limited

10-11 Taber Place Crittall Road Witham Essex CM8 3YP England

Tel: 01376 501255 Telefax: 01376 501312

International Tel: +44 1376 501255 Fax: +44 1376 501312

email: sales@radiodata.co.uk

URL: www.radiodata.co.uk