



RM9600 Radio Modem

Application Note

PELCO P & PELCO D PROTOCOLS

RS485 Communications Over Radio

Benefits

Permits wireless connectivity of the Pelco telemetry keyboard and Spectra dome

Built-in radio path test facility

Configurable frequency of operation

Configurable addressing for security

Removes RS485 data cables

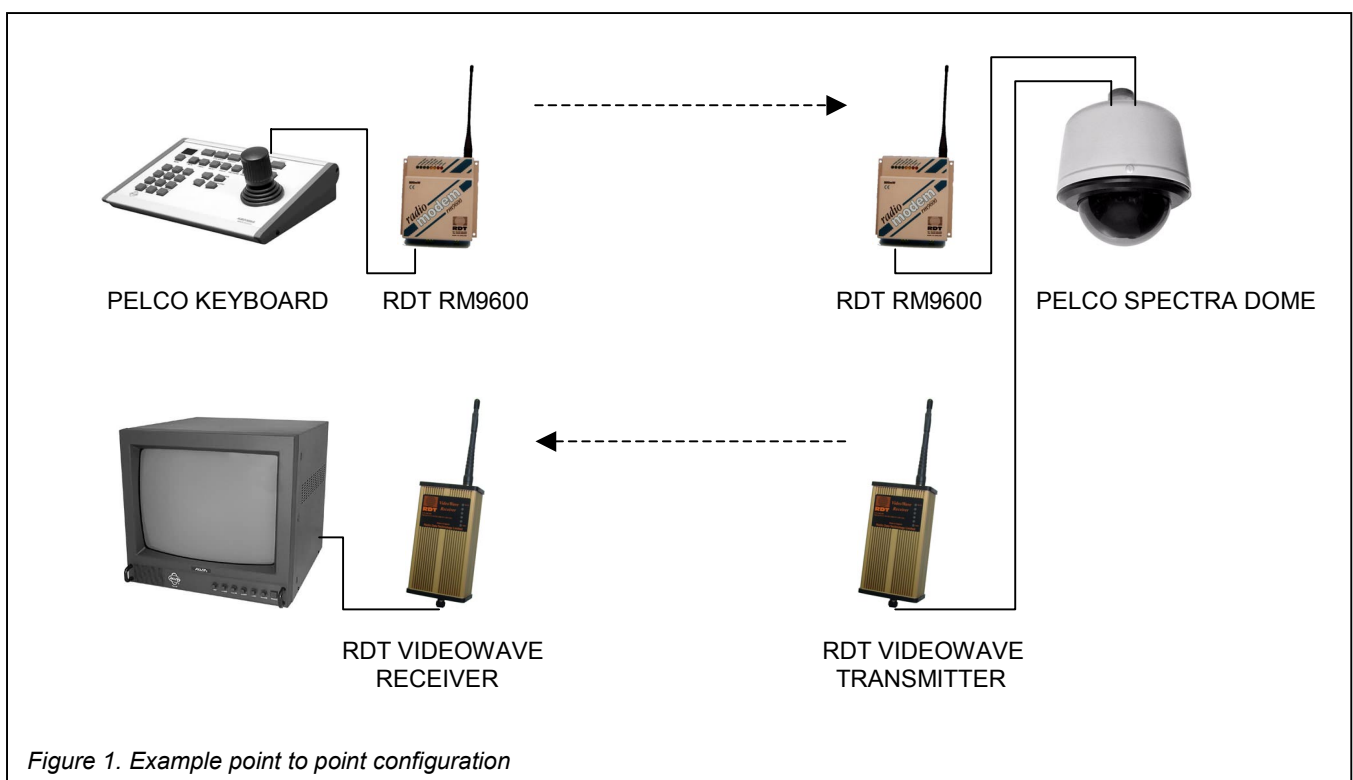

Brief Description

The RM9600 Radio Modem is a secure radio data modem used for a variety of data transfer applications, including telemetry control. The use of radio for such tasks can permit a more cost-effective and flexible solution than with cabled methods. Combining the flexibility of radio data transfer with the Pelco telemetry controller and Spectra dome permits the construction of a system with rapid installation benefits without depending upon cables.

Application note produced with the co-operation of:

Pelco UK
Indigo House
Mulberry Business Park
Fishponds Road
Wokingham
Berkshire RG41 2GY

Tel: +44 (0)870 220 2622
Fax: +44 (0)870 220 2633
Email: UKSales@pelco.com
Web: www.pelco.com

Description of Application

The Pelco telemetry controller and Spectra dome can communicate across the radio link utilizing RS422 protocols at 4800baud (Pelco P protocol) or 2400baud (Pelco D protocol) in simplex mode. Wireless video transmission is possible using the RDT Videowave series transmitters and receivers. The standard radio modem unit required at all locations is the RM9600 model, which is available in the following versions:

Part Number	Description	Antenna connection	Weatherproof
RM9600	Radio modem board module	SMA	No
RM9600B	Radio modem in aluminium enclosure	BNC	No
RM9600E	Radio modem + mains PSU in IP67 enclosure	BNC or N-type	Yes
VTX1394SED	Radio modem + 1394MHz colour video transmitter & mains PSU in IP67 enclosure	BNC or N-type	Yes
VRX1394SED	Radio modem + 1394MHz colour video receiver & mains PSU in IP67 enclosure	BNC or N-type	Yes
VTX2400ENCD	Radio modem + 2400MHz colour video transmitter & mains PSU in IP67 enclosure	BNC or N-type	Yes
VRX2400ENCD	Radio modem + 2400MHz colour video receiver & mains PSU in IP67 enclosure	BNC or N-type	Yes

Please refer to the RM9600 and videowave data sheets for further details of the above options.

The radio modem incorporates a synthesized UHF transceiver, tested to ETS 300 220-3 for operation in the UK without a license. Various approvals are held for worldwide operation. Configuration is via the rotary and DIL switches on the RM9600 which allow a band of up to 64 radio channels to be selected, (no. of channels available is dependant on regulations in the country of operation, UK specification has 15 channels), along with the serial interface baud rate, parity and character length.

Radio Modem Board Layout

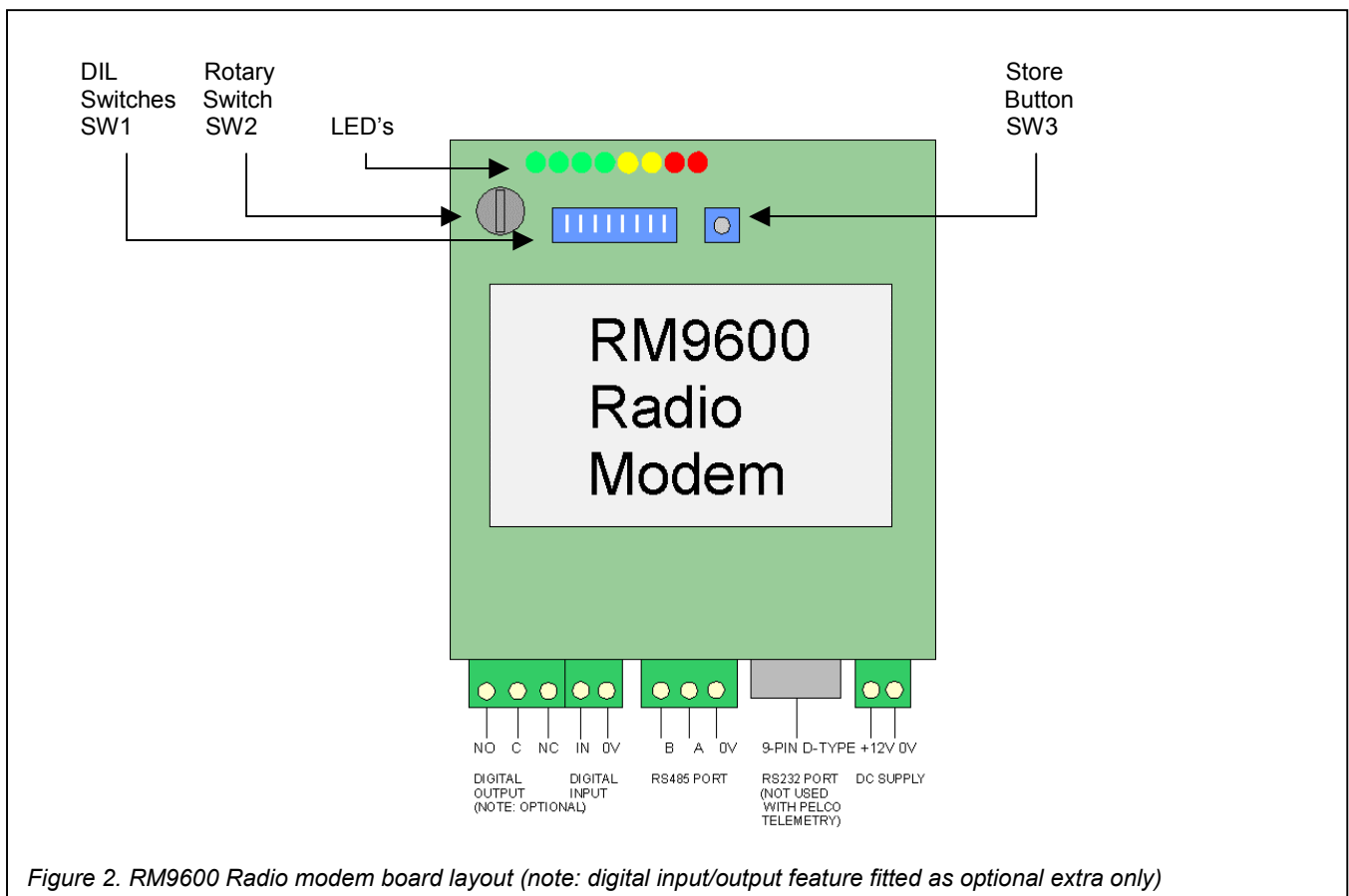

Connection and Configuration Details

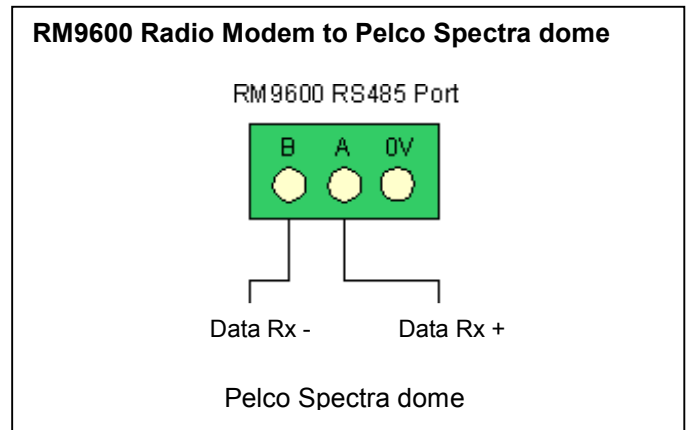
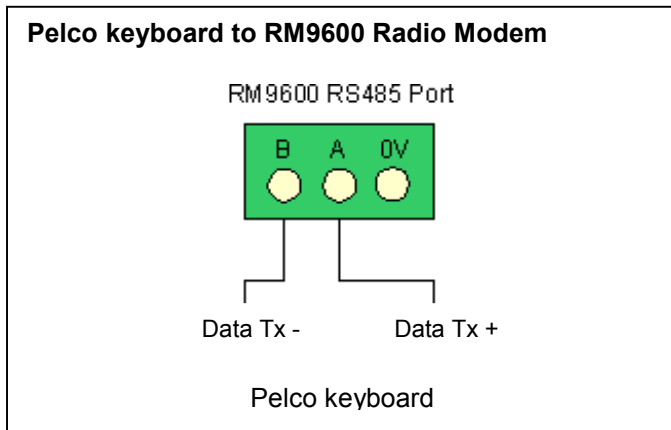

Important Note: Ensure that the antenna is connected at all times when the RM9600 is powered.

Configuration for use with Pelco P protocol:

- 1) With RM9600 powered, turn rotary switch SW2 to position F, and then press the store button SW3. This will reset the unit to factory default settings.
- 2) Turn the rotary switch SW2 to position 3. Set the DIL switches SW1 numbers 1 to 7 all OFF, and number 8 ON. Press the store button SW3. This sets the unit to RS485 operation.
- 3) Turn the rotary switch SW2 to position 5. Set DIL switches SW1 numbers 2, 4, 5, 6, & 8 OFF, and switch numbers 1, 3, & 7 ON. Press the store button SW3. This sets the radio modem serial interface to 4800baud, 8 data bits, 1 stop bit, no parity, as required for Pelco P protocol.
- 4) Turn the rotary switch back to position 0.
- 5) Set DIL switches for required power level and RF channel (see RM9600 user manual). It is advised in most cases that the lowest power level be selected at first, then increase if necessary.

Configuration for use with Pelco D protocol:

- 1) With RM9600 powered, turn rotary switch SW2 to position F, and then press the store button SW3. This will reset the unit to factory default settings.
- 2) Turn the rotary switch SW2 to position 3. Set the DIL switches SW1 numbers 1 to 7 all OFF, and number 8 ON. Press the store button SW3. This sets the unit to RS485 operation.
- 3) Turn the rotary switch SW2 to position 5. Set DIL switches SW1 numbers 2, 3, 4, 5, 6, & 8 OFF, and switch numbers 1 & 7 ON. Press the store button SW3. This sets the radio modem serial interface to 2400baud, 8 data bits, 1 stop bit, no parity, as required for Pelco D protocol.
- 4) Turn the rotary switch back to position 0.
- 5) Set DIL switches for required power level and RF channel (see RM9600 user manual). It is advised in most cases that the lowest power level be selected at first, then increase if necessary.

Antenna Selection

RDT can supply a range of antennas suitable for various applications. The table below gives an approximate guide to the distances that are achievable using different antenna types.

Part Number	Description	Range	Gain	Connection	Mounting Requirements
ANT006A	½ wave whip. Omni-directional.	800m	-3dB	BNC	Direct to enclosure
ANT008	End-fed dipole. Omni-directional.	5km	0dB	N-type	50mm dia. pole
ANT009-8	8 element yagi. Directional (40°)	10km	10dB	N-type	50mm dia. pole

LED Operation

The LED's D10 to D17 on the RM9600 radio modem will provide different functions depending on the mode of operation selected by the rotary switch SW2. For example: In test mode they will indicate that the transmitter is active, or the received signal strength. In configuration modes, they will indicate the stored settings. In normal operating mode (Run Mode: Rotary switch SW2 position 0) they will indicate the following functions:

- D10 Green LED – RfCD (Carrier Detect). Indicates that the receiver is detecting a carrier signal on the selected Rf channel. For example, on a unit connected to the Spectra dome this LED will illuminate when data is being received over the air from the remote Pelco controller. Illumination of this LED when data is not being received may indicate interference on the selected Rf channel.
- D11 Green LED – TxFull (Buffer Full). Indicates that the RM9600's data buffer is full.
- D12 Green LED – Rx D (Receive Serial Data). Indicates that data is being received via the serial port. Illumination of this LED should be followed by D15 (RfTx) to indicate that the received serial data is being transmitted. On a unit connected to a Pelco controller, if the D12 LED does not illuminate when a command is sent from the controller, check the RS485 serial data connection.
- D13 Green LED – Tx D (Transmit Serial Data). Indicates that data is being output via the serial port. For example, on a unit connected to the Spectra dome, this LED will illuminate following the receipt of data over the air from the Pelco controller to indicate that the data is being output to the dome.
- D14 Yellow LED – RfRx (Rf Receive). Indicates that the radio transceiver is currently in receive mode. This is the normal status for any unit when data is not being received via the serial port.
- D15 Yellow LED – RfTx (Rf Transmit). Indicates that the radio transceiver is currently in transmit mode. This will follow receipt of data via the serial port (indicated by illumination of the D12 LED). The status of the D15 LED will always oppose that of the D14 LED (RfRx).
- D16 Red LED - +10.5V (Supply Voltage). Indicates the presence of DC supply voltage. This LED will remain illuminated at all times when the radio modem is in run mode.
- D17 Red LED - +5V (Supply Voltage). Indicates the presence of DC supply voltage. This LED will remain illuminated at all times when the radio modem is in run mode.

Please refer to the RM9600 user manual for further information on configuration, test, and run modes.

For supply of the RM9600 radio modems or further information on this or any other application, please contact your nearest RDT distributor.

Radio Data Technology Limited

10-11 Taber Place Crittall Road Witham Essex CM8 3YP England

Tel: 01376 501255 Telefax: 01376 501312

International Tel: +44 1376 501255 Fax: +44 1376 501312

email: sales@radiodata.co.uk

URL: www.radiodata.co.uk

RDT does not assume any responsibility for the use of the products described. No product patents are implied and RDT reserves the right to change the said products without notice at any time.