



# RM9600 Radio Modem

## Application Note

### DEDICATED MICROS DIGITAL SPRITE 2 & DENNARD 2055 DOME CAMERA RS485 Communications Over Radio

#### Benefits

Permits wireless connectivity of the Dedicated Micros DS2 and Dennard 2055 dome

Built-in radio path test facility

Configurable frequency of operation

Configurable addressing for security

Removes RS485 data cables

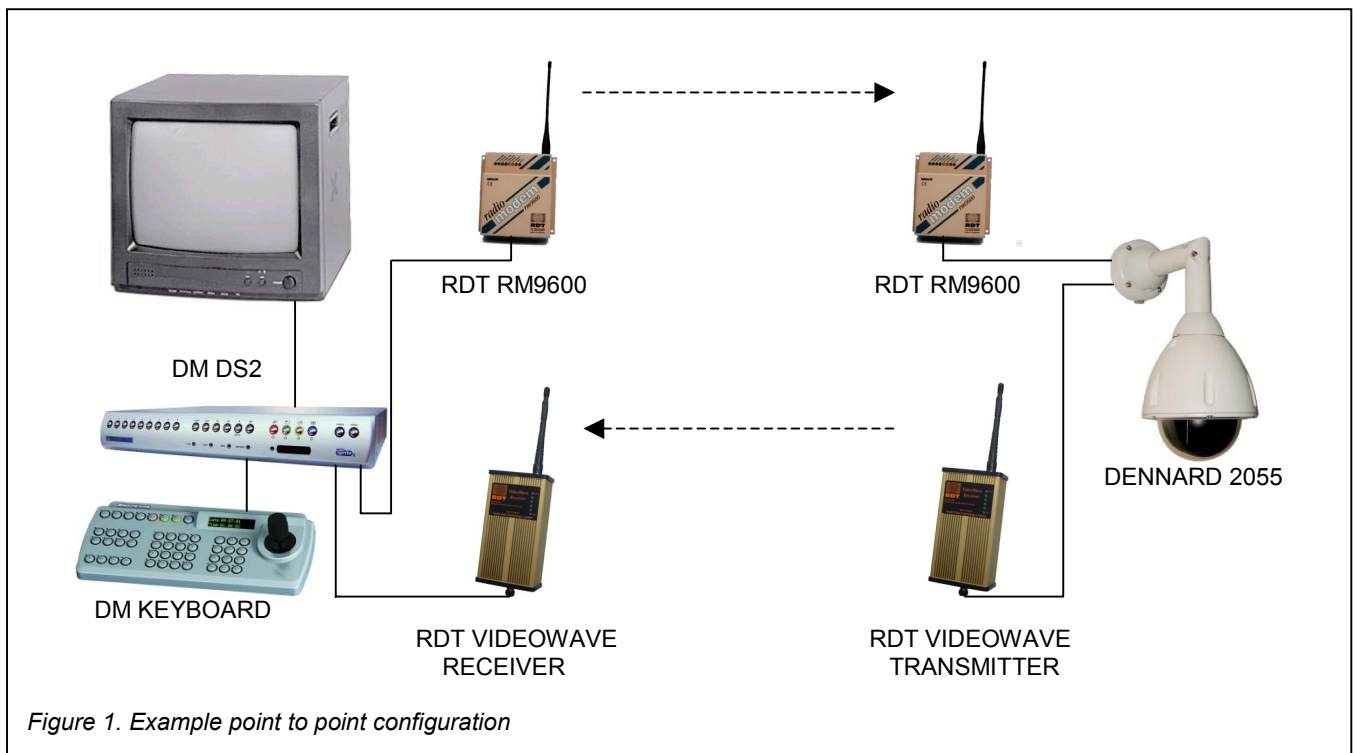

#### Brief Description

The RM9600 Radio Modem is a secure radio data modem used for a variety of data transfer applications, including telemetry control. The use of radio for such tasks can permit a more cost-effective and flexible solution than with cabled methods. Combining the flexibility of radio data transfer with the Dedicated Micros Digital Sprite 2 and Dennard 2055 dome permits the construction of a system with rapid installation benefits without depending upon cables.

*For further information on Dedicated Micros and Dennard products please contact:*

**Dedicated Micros UK**  
11 Oak Street,  
Swinton,  
Manchester M27 4FL  
Tel: + 44 (0) 161 727 3244  
Fax: + 44 (0) 161 727 3266  
Web: [www.dedicatedmicros.com](http://www.dedicatedmicros.com)

**Dennard Ltd.**  
55 Fleet Road  
Hants  
Tel +44 (0) 1252 61 48 84  
Fax +44 (0) 1252 62 60 13  
Web: [www.dennard-cctv.com](http://www.dennard-cctv.com)

## Description of Application

The Dedicated Micros DS2 and Dennard 2055 dome can communicate across the radio link utilizing RS485 protocols in half duplex mode. The standard radio modem unit required at all locations is the RM9600 model, which is available in the following versions:

Part Number	Description	Antenna connection	Weatherproof
RM9600	Radio modem board module	SMA	No
RM9600B	Radio modem in aluminium enclosure	BNC	No
RM9600E	Radio modem + mains PSU in IP67 enclosure	BNC or N-type	Yes
VTX1394SED	Radio modem + 1394MHz colour video transmitter & mains PSU in IP67 enclosure	BNC or N-type	Yes
VRX1394SED	Radio modem + 1394MHz colour video receiver & mains PSU in IP67 enclosure	BNC or N-type	Yes
VTX2400ENCD	Radio modem + 2400MHz colour video transmitter & mains PSU in IP67 enclosure	BNC or N-type	Yes
VRX2400ENCD	Radio modem + 2400MHz colour video receiver & mains PSU in IP67 enclosure	BNC or N-type	Yes

Please refer to the RM9600 and videowave data sheets for further details of the above options.

The radio modem incorporates a synthesized UHF transceiver, tested to ETS 300 220-3 for operation in the UK without a license. Various approvals are held for worldwide operation. Configuration is via the rotary and DIL switches on the RM9600 which allow a band of up to 64 radio channels to be selected, (no. of channels available is dependant on regulations in the country of operation, UK specification has 15 channels), along with the serial interface baud rate, parity and character length.

## Radio Modem Board Layout

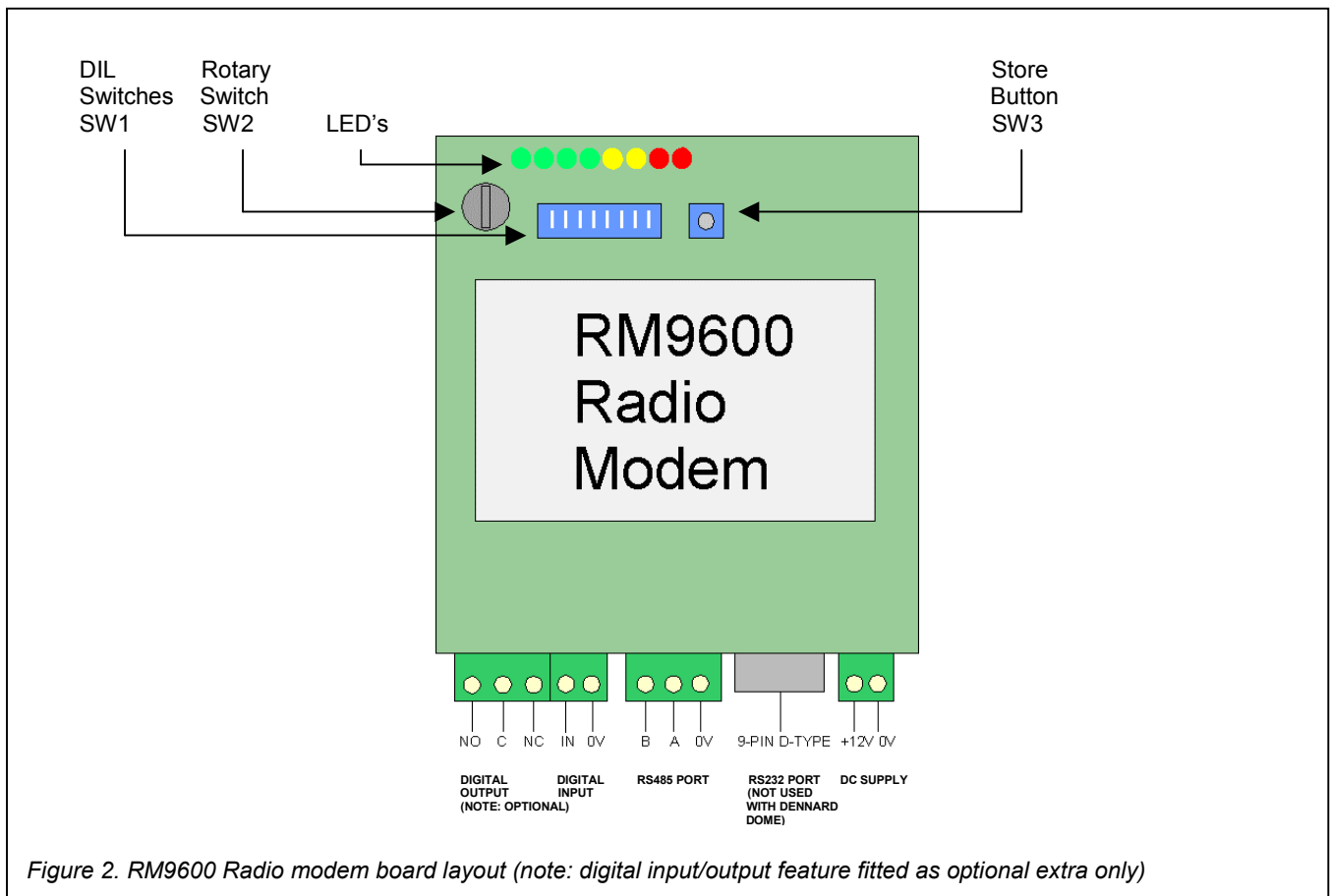

## Connection and Configuration Details

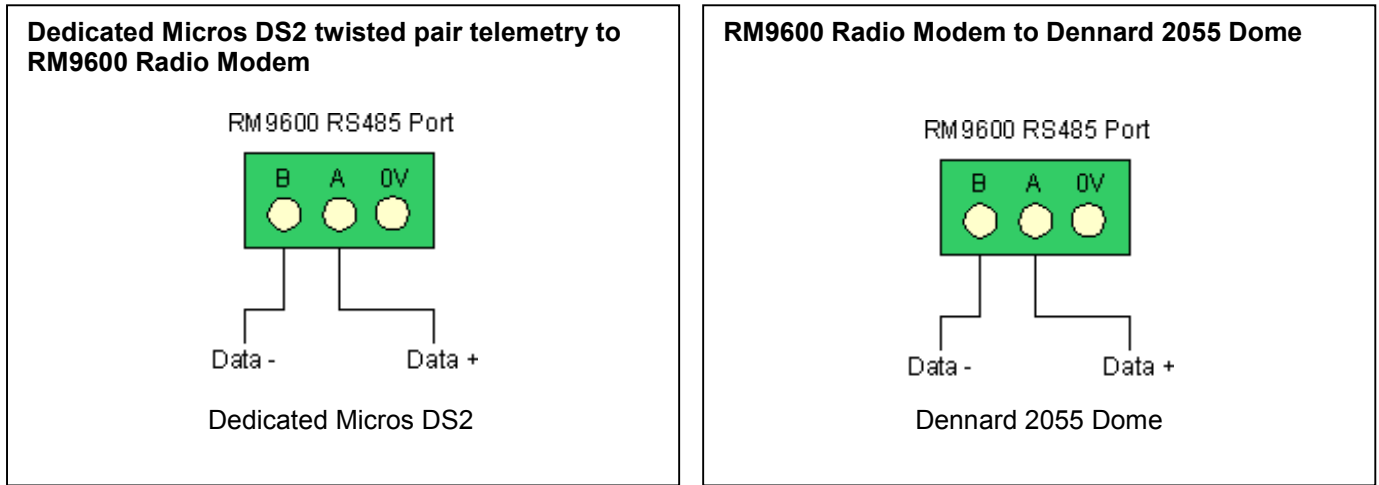

How to configure the RM9600 radio modem to operate with the DM DS2 & Dennard 2055.

- Step 1 With RM9600 powered, turn the rotary Switch (SW2) to position 'F' and then press the 'STORE' button (SW3). This will reset the modem to factory settings.
- Step 2 Turn the rotary switch to position '3' (operating mode selection). Set DIL switch (SW1) number 8 ON and the rest OFF. Press the STORE button. This selects RS485 operation.
- Step 3 Turn Rotary switch back to position '0' (run mode).
- Step 4 Set DIL switches for required power level and RF channel. (see RM9600 User Manual)
- Step 5 Repeat steps 1 to 4 for each modem used.

## Antenna Selection

RDT can supply a range of antennas suitable for various applications. The table below gives an approximate guide to the distances that are achievable using different antenna types.

Part Number	Description	Range	Gain	Connection	Mounting Requirements
ANT0006A	½ wave whip. Omni-directional.	800m	-3dB	BNC	Direct to enclosure
ANT0008	End-fed dipole. Omni-directional.	5km	0dB	N-type	50mm dia. pole
ANT0009-8	8 element yagi. Directional (40°)	10km	10dB	N-type	50mm dia. pole

## LED Operation

The LED's D10 to D17 on the RM9600 radio modem will provide different functions depending on the mode of operation selected by the rotary switch SW2. For example: In test mode they will indicate that the transmitter is active, or the received signal strength. In configuration modes, they will indicate the stored settings. In normal operating mode (Run Mode: Rotary switch SW2 position 0) they will indicate the following functions:

- D10 Green LED – RfCD (Carrier Detect). Indicates that the receiver is detecting a carrier signal on the selected Rf channel. For example, on a unit connected to the 2055 dome this LED will illuminate when data is being received over the air from the remote DS2. Illumination of this LED when data is not being received may indicate interference on the selected Rf channel.
- D11 Green LED – TxFull (Buffer Full). Indicates that the RM9600's data buffer is full.
- D12 Green LED – RxD (Receive Serial Data). Indicates that data is being received via the serial port. Illumination of this LED should be followed by D15 (RfTx) to indicate that the received serial data is being transmitted. On a unit connected to a DS2, if the D12 LED does not illuminate when a command is sent from the controller, check the RS485 serial data connection and that the DS2 is configured for twisted pair telemetry.
- D13 Green LED – TxD (Transmit Serial Data). Indicates that data is being output via the serial port. For example, on a unit connected to the 2055 dome, this LED will illuminate following the receipt of data over the air from the DS2 controller to indicate that the data is being output to the dome.
- D14 Yellow LED – RfRx (Rf Receive). Indicates that the radio transceiver is currently in receive mode. This is the normal status for any unit when data is not being received via the serial port.
- D15 Yellow LED – RfTx (Rf Transmit). Indicates that the radio transceiver is currently in transmit mode. This will follow receipt of data via the serial port (indicated by illumination of the D12 LED). The status of the D15 LED will always oppose that of the D14 LED (RfRx).
- D16 Red LED - +10.5V (Supply Voltage). Indicates the presence of DC supply voltage. This LED will remain illuminated at all times when the radio modem is in run mode.
- D17 Red LED - +5V (Supply Voltage). Indicates the presence of DC supply voltage. This LED will remain illuminated at all times when the radio modem is in run mode.

Please refer to the RM9600 user manual for further information on configuration, test, and run modes.

For further information on this or any other application for the RM9600 Radio Modem, please contact your nearest RDT distributor.

### **Radio Data Technology Limited**

10 Taber Place Crittall Road Witham Essex CM8 3YP England

Tel: 01376 501255 Telefax: 01376 501312

International Tel: +44 1376 501255 Fax: +44 1376 501312

email: [sales@radiodata.co.uk](mailto:sales@radiodata.co.uk)

URL: [www.radiodata.co.uk](http://www.radiodata.co.uk)

RDT does not assume any responsibility for the use of the products described. No product patents are implied and RDT reserves the right to change the said products without notice at any time.